

ACO INFRASTRUCTURE DRWG# XIXR-GC-1 www.aconz.co.nz	INSTALLATION DRAWING	ACO Limited New Zealand Ph: 0800 448 080 www.aconz.co.nz sales@aconz.co.nz
	Qmax 225/300/350 Load Class G: Concrete	

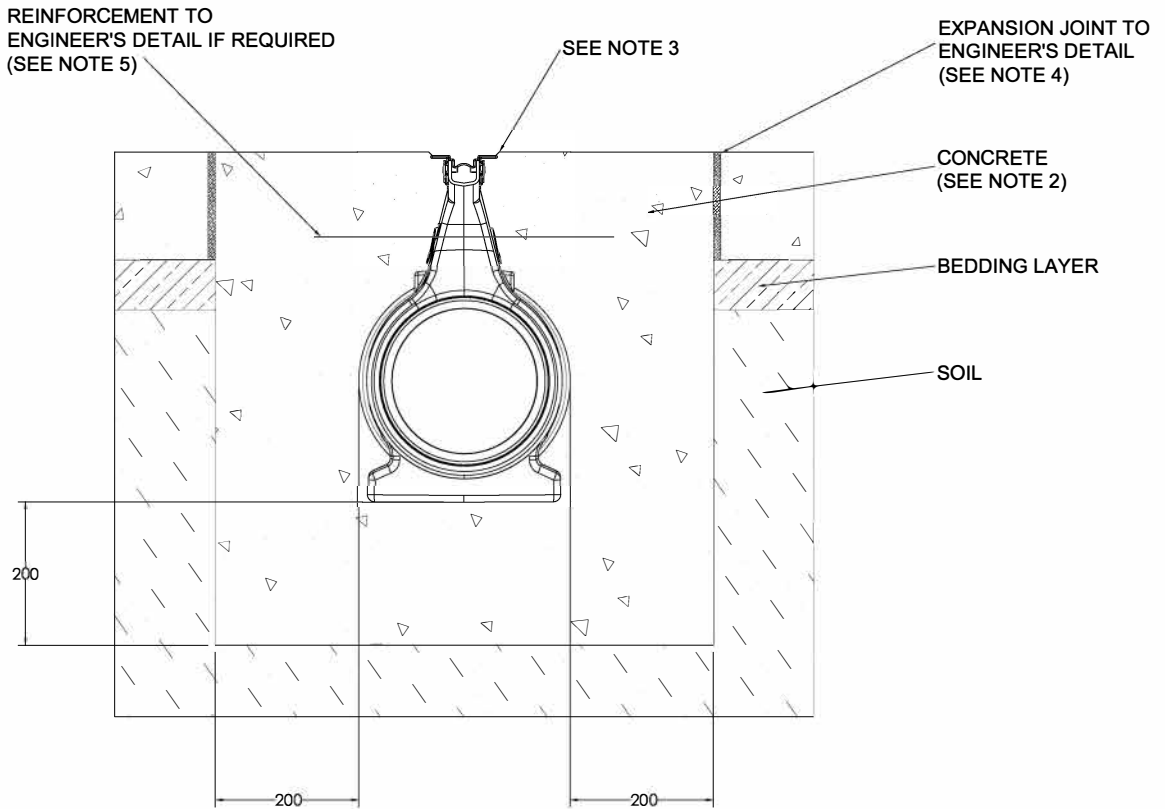

NOTES:

1. Specific site conditions may require an increase in these dimensions or reinforcement. It is the customer's responsibility to ensure the concrete encasement is designed for the application. *Engineering advice may be required.*
2. A minimum concrete strength of 40MPa is recommended. The concrete should be vibrated to eliminate air pockets.
3. The finished level of the concrete surround must be approx. 3-5mm above the top of the channel slot. During site work and concrete pour, ensure that the plastic protective strip (supplied with Q-Flow slot) is not damaged or displaced, in order to prevent debris entering the channel during construction.
4. Expansion and crack control joints are recommended to protect the channel and the concrete surround. *Engineering advice may be required.*
5. Slab reinforcement (if any) can be continued through the Qmax arch detail under the slot. *Engineering advice may be required.*

ACO INFRASTRUCTURE DRWG# XIXR-GC-1 www.aconz.co.nz	SPECIFICATION CLAUSE	ACO Limited New Zealand Ph: 0800 448 080 www.aconz.co.nz sales@aconz.co.nz
	Qmax 225 / 300 / 350* System	

The slot drainage system shall be ACO's **Qmax 225 / 300 / 350*** system as manufactured by ACO Pty Ltd.

ACO's **Qmax 225 / 300 / 350*** polyethylene (PE) channels have a stiff rib design providing high strength and a pavement beam feature allowing necessary keying of concrete. The 2000mm long lightweight PE channels have a simple push-fit male/female watertight connection and levelling feet for ease of installation and stability.

The **constant depth / stepped*** system shall be complete with the Q-Flow galvanised steel 26mm wide slot.

ACO's **Qmax 225 / 300 / 350*** channels shall be connected to a Qmax 225/300/350 **access unit / pit*** with slotted grate (Optional).*

All materials and components within the scope of this system shall be obtained from this manufacturer and the work shall be carried out as specified on the drawings.

***Delete where appropriate**