

Qmax - 350 channel with Q-Flow galvanised steel slot

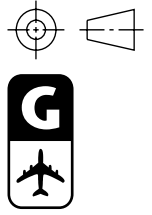

Two metre channel

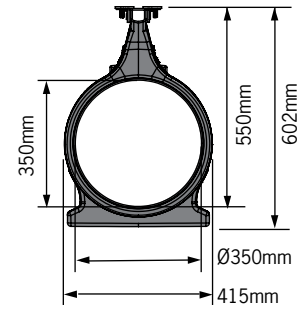
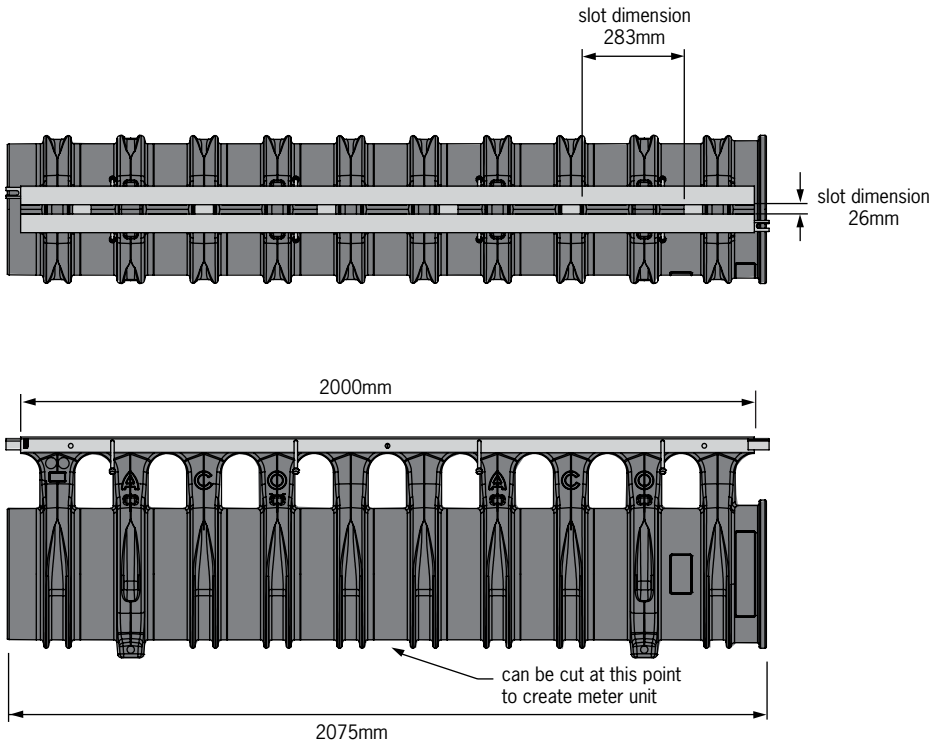

End cap

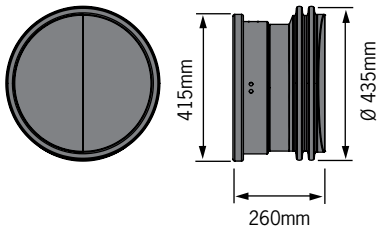

ACO Specification Information

ACO INFRASTRUCTURE

Qmax - 350 channel with Q-Flow galvanised steel slot



ACO Specification Information

Description	Part	Invert	Wgt
	No	mm	kg
Qmax 350 channel with Q-Flow galvanised steel slot - 2m	32812	550	24.0
Accessories			
Qmax 350 End cap - 0.026m	42351	-	2.8

Typical Qmax 350 connection to pit

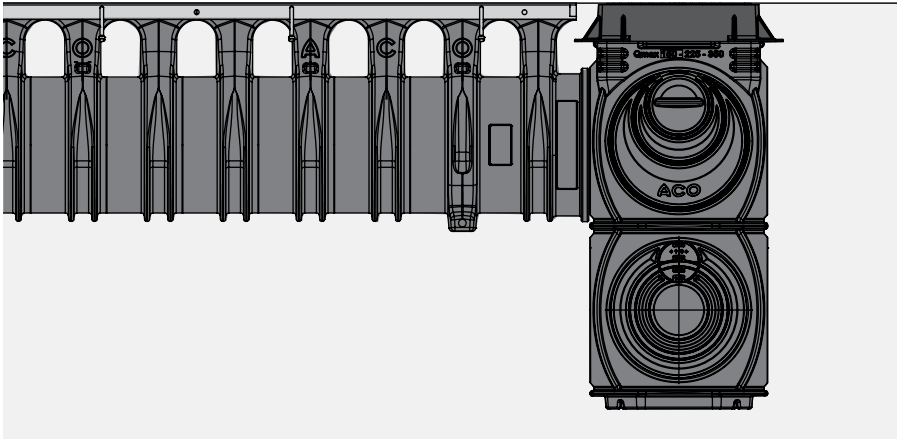

Qmax 350 channel

Qmax 225/350 Pit -see appropriate Spec Info

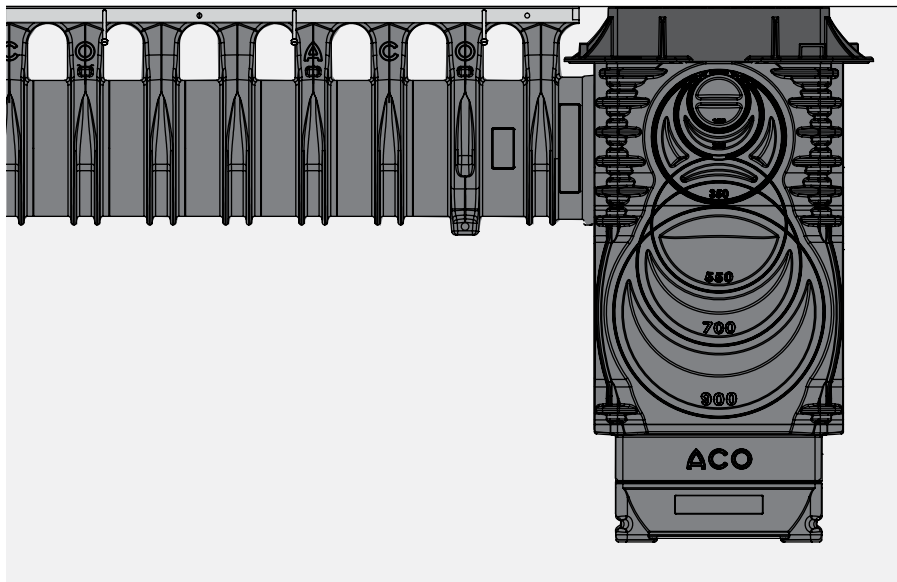

Qmax 350 channel

Qmax Universal Pit -see appropriate Spec Info

Specifications

General

The surface drainage system shall be ACO Qmax 350 with galvanised steel Q-Flow top as manufactured by ACO Limited or equal approved.

Materials

The trench system bodies shall be manufactured from medium density polyethylene with:

Compressive strength: 58,250 kN/m²
 Flexural strength: 15,350 kN/m²
 Water absorption 0.31%

The nominal clear opening shall be 350mm with unit overall width of 415mm. Units shall be manufactured with a neutral invert of 550mm. Each unit will feature a full radius in the channel bottom and a male to female interconnecting end profile, a rubber seal shall be fitted to the bell end of the channel unit. Units shall have molded anchoring features on the outside wall to ensure maximum mechanical bond to the surrounding bedding material and pavement surface.

Grate Unit

Grates shall be factory fitted to MDPE bodies to provide a monolithic unit. Water intake area per 2 metre unit will be 60,320mm².

Pit

See appropriate spec info for pit information.

Installation

The trench drain system shall be installed in accordance with the manufacturer's installation instructions and recommendations.

ACO Limited
New Zealand
 Ph: 0800 448 080
 www.aconz.co.nz
 info@aconz.co.nz



© July 2017 ACO Limited. All reasonable care has been taken in compiling the information in this document. All recommendations and suggestions on the use of ACO products are made without guarantee since the conditions of use are beyond the control of the company. It is the customer's responsibility to ensure that each product is fit for its intended purpose and that the actual conditions are suitable. ACO Limited pursues a policy of continuous product development and reserves the right to amend specifications without notice.