

SIT Pit Assembly - 450mm deep base

Galvanised lid - 25 tonne rated

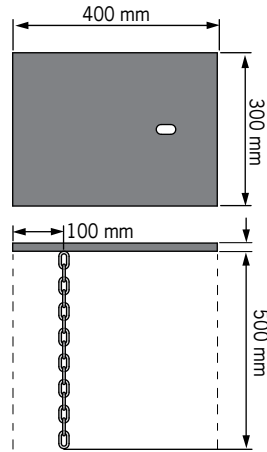

SIT PIT Collar

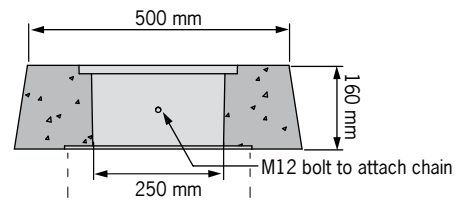
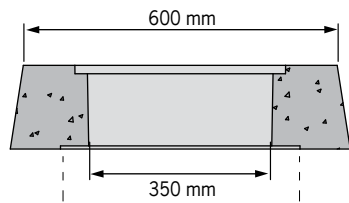
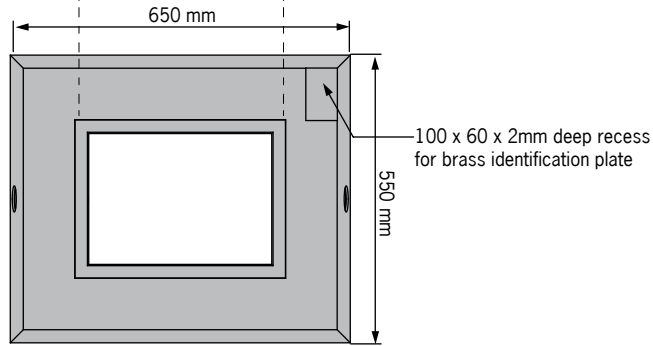

SIT PIT Base

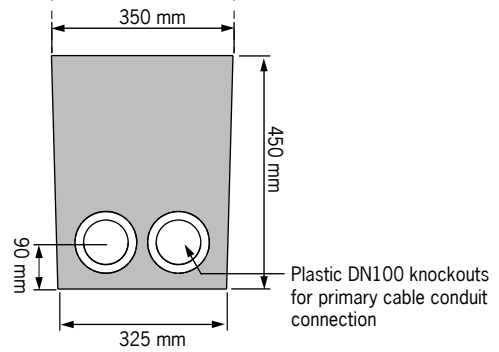
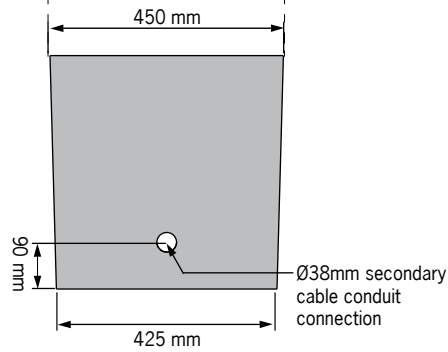
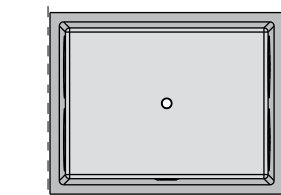

ACO Specification Information

ACO CABLEMATE

SIT Pit Assembly - 450mm deep base

Cable pit, collar and lid

Description	Part No	Depth mm	Weight kg
SIT Pit Lid and Collar Assembled	142322	600*	96
SIT Pit Base – 450mm deep	142320		25
Universal Lifting Key	84306	-	1

* Overall height of combined parts

Specifications

General

The cable pit shall be ACO SIT Pit - concrete pit with steel lid as supplied by ACO Limited. or equal approved.

Materials

The pit body shall be manufactured from polymer concrete with:

Electrical resistivity 1 x 10⁸ Ω /sq
 Compressive strength: 96MPa
 Flexural strength: 27MPa
 Water absorption 0.07%
 Frost proof
 Salt proof
 Dilute acid and alkali resistant
 Surface burn characteristics of the material shall comply with UL 723

The nominal clear opening shall be 250mm x 350mm. Units shall be manufactured with a overall depth of 600mm.

Lid

The pit shall be covered with a steel lid rated to 25 tonnes.

Installation

The pit shall be installed in accordance with the manufacturer's installation instructions and recommendations.

* delete as applicable

ACO Limited
New Zealand
 Ph: 0800 448 080
 www.aconz.co.nz
 info@aconz.co.nz

© March 2018 ACO Limited. All reasonable care has been taken in compiling the information in this document. All recommendations and suggestions on the use of ACO products are made without guarantee since the conditions of use are beyond the control of the company. It is the customer's responsibility to ensure that each product is fit for its intended purpose and that the actual conditions are suitable. ACO Limited. pursues a policy of continuous product development and reserves the right to amend specifications without notice.

