

ACO Threshold - OnePour™

Single pour drainage system for level threshold building entries

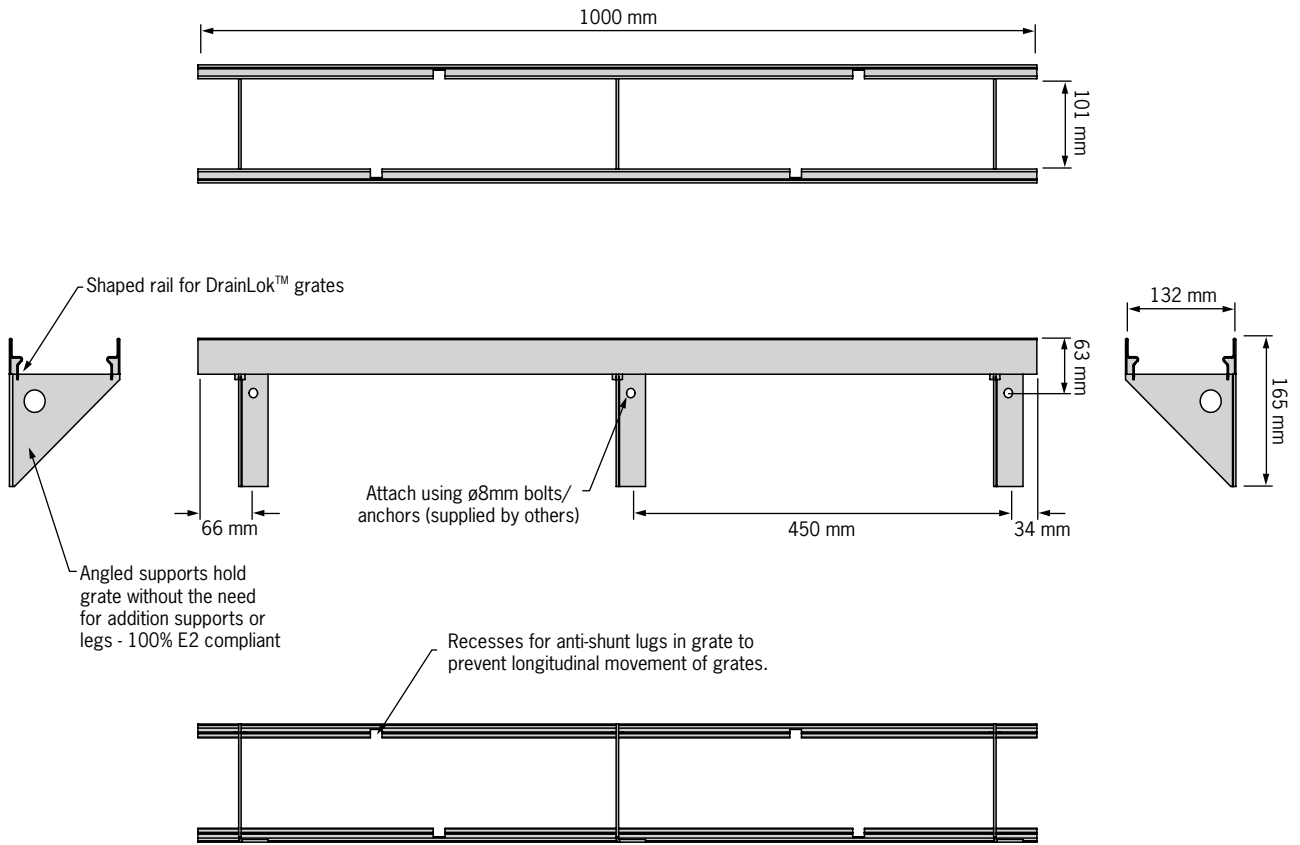

ACO Specification Information

ACO BUILDLINE

ACO Threshold - OnePour™

Parts Table

	Part No		Length mm	Weight Kgs
	Galv	S/S		
OnePour™ frame - (1m)	296033	296034	1000	4.3

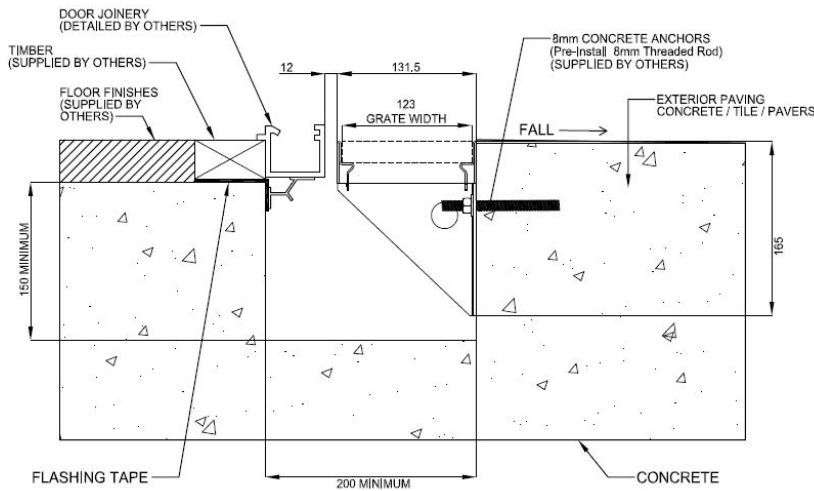

Specifications

General

The threshold drainage system shall be ACO BuildLine OnePour™ complete with gratings secured with 'DrainLok™' locking as manufactured by ACO Ltd. or approved equal.

Materials

The frame system shall be manufactured from galvanised/stainless* steel.

The frame shall provide a 100mm wide drainage opening and a 12mm open slot between the frame and the door assembly. A minimum 200mm wide drainage channel can be formed beneath the frame system.

The OnePour™ unit shall comply fully with E2 External Moisture of the New Zealand Building Code. The Grate shall be fully supported without additional supports or legs impede drainage channel and are completely interdependent of joinery/cladding.

Grates

A selection of ACO DrainLok™ grates, complying with Clause 9—AS 1428.2, Access and Mobility, ensuring safe passage of walking canes and wheelchairs, are available.

Grates shall be specified. See separate ACO Spec Info grate sheets for details. After removal of grates and there shall be uninterrupted access to the trench to aid maintenance.

Installation

The trench drain system shall be installed in accordance with the manufacturer's installation instructions and recommendations.

* delete as necessary

ACO Limited

Unit F/6 Percival Gull Place
Mangere, Auckland 2022
New Zealand

Tel: 0800 448 080
Tel: +64 (0)9 815 9500
Fax: +64 (0)9 255 5114

Electronic Contact
info@aconz.co.nz
www.acoself.co.nz

© October 2020 ACO Limited.

All reasonable care has been taken in compiling the information in this document. All recommendations and suggestions on the use of ACO products are made without guarantee since the conditions of use are beyond the control of the Company. It is the customer's responsibility to ensure that each product is fit for its intended purpose and that the actual conditions of use are suitable. ACO Limited reserves the right to change products and specifications without notice.

Re-order LENZ00??

October 2020

